

CPQ quote: QUO0000004904 Rev: 2

Date & revision: 2021-11-08 rev.1

| | |
|--------------------------------|---------|
| General exterior | page 2 |
| Curbside exterior | page 3 |
| Streetside exterior | page 4 |
| Front & rear exterior | page 5 |
| Curbside interior wall | page 6 |
| Streetside interior wall | page 7 |
| Front interior wall | page 8 |
| Rear interior wall | page 9 |
| Floor view | page 10 |
| Ceiling view | page 11 |
| Front console | page 12 |
| Rear streetside console | page 13 |

DISCLAIMERS

Demers makes every effort to maintain the accuracy and quality of the information provided in these drawings. However, Demers cannot guarantee and assumes no legal liability or responsibility for the accuracy or completeness of the information provided. The information contained in these drawings is for general guidance only. You should always develop your quote and send to Demers for engineering validation to the feasibility of the custom options according to the specific configuration required by the customer.

Should there be any discrepancies between the CPQ configurator, the CPQ quote or sale sheet and these drawings; the CPQ configurator, the CPQ quote or sale sheet will take precedence. These drawings are subject to change by engineering during the construction process of the vehicle. Dimensional data for information only. The copyright of all content in these drawings is owned by Demers and/or the various manufacturers of our equipment. These drawings in part or whole cannot be changed, reproduced, stored in or transmitted onto any website or social media without the prior written consent from Demers.

TSE - Ford Transit Van T250

Bulldog Stock Unit



General exterior

Date: 2021-11-08 rev.1
Scale: 1:40
Draftman: TT

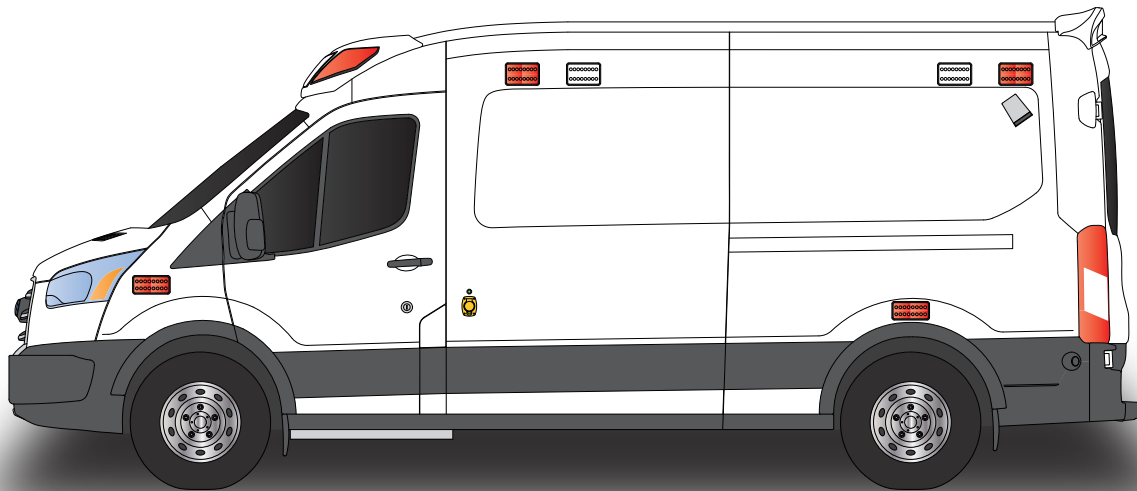
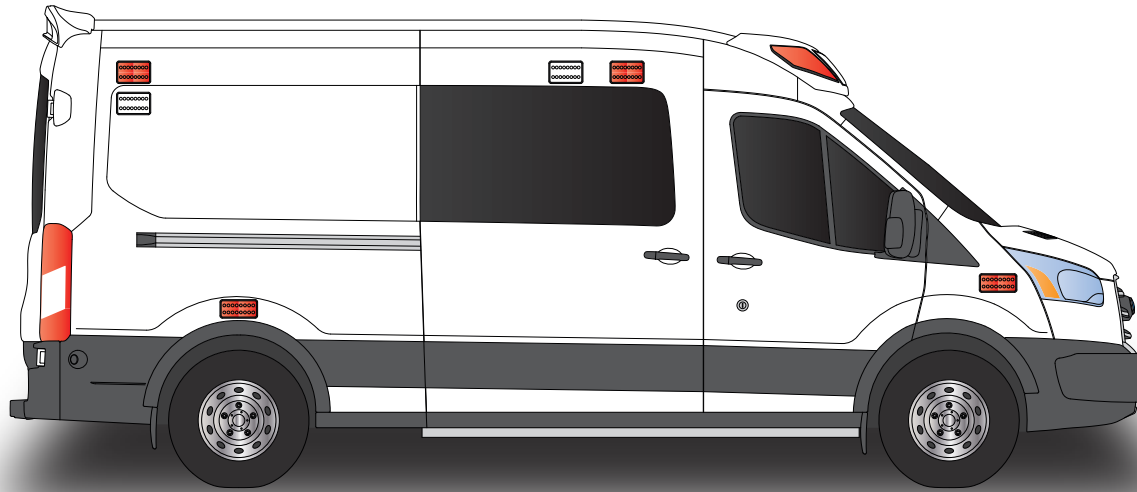

Curbside exterior

Date: 2021-11-08 rev.1
Scale: 1:25
Draftman: TT

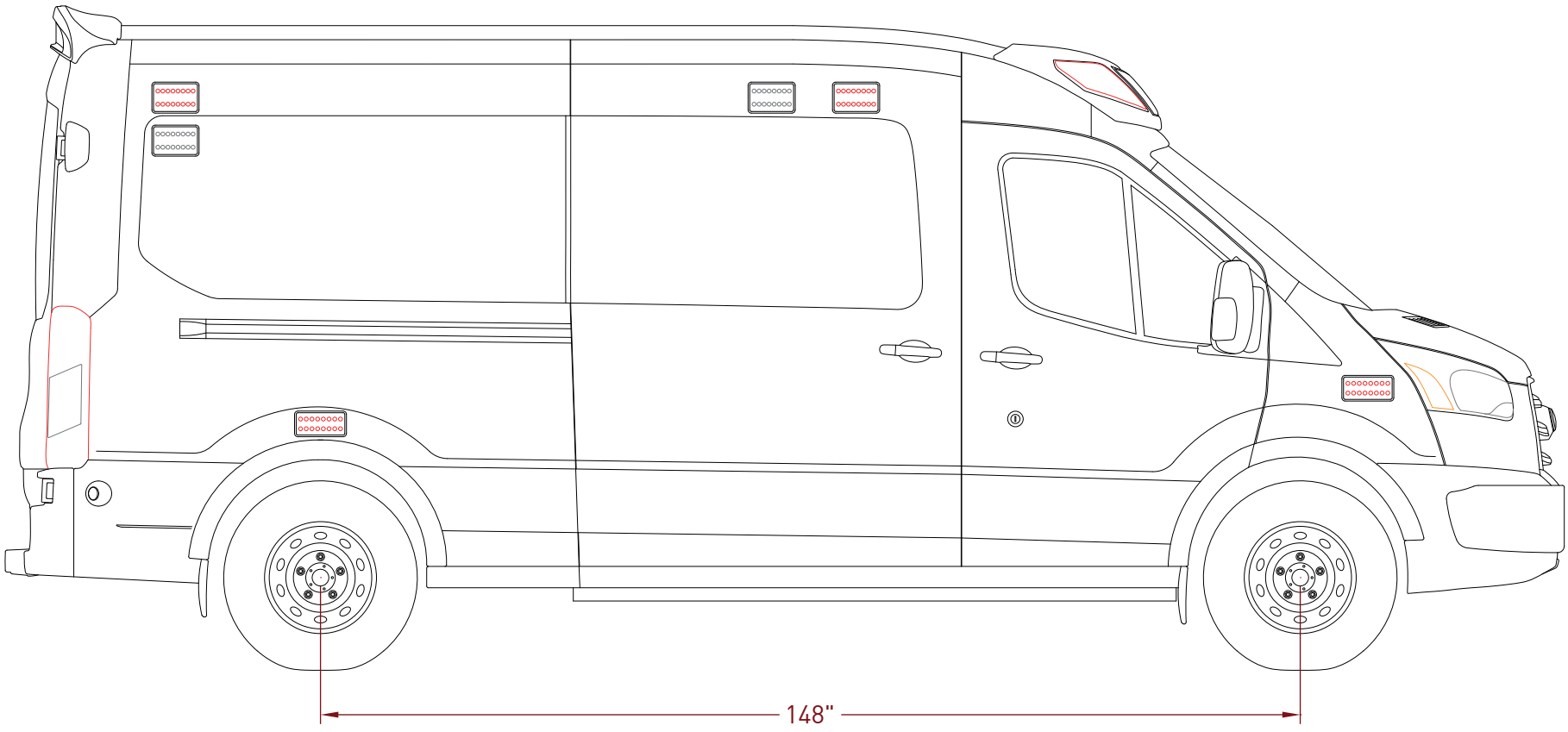

Streetside exterior

Date: 2021-11-08 rev.1
Scale: 1:25
Draftman: TT

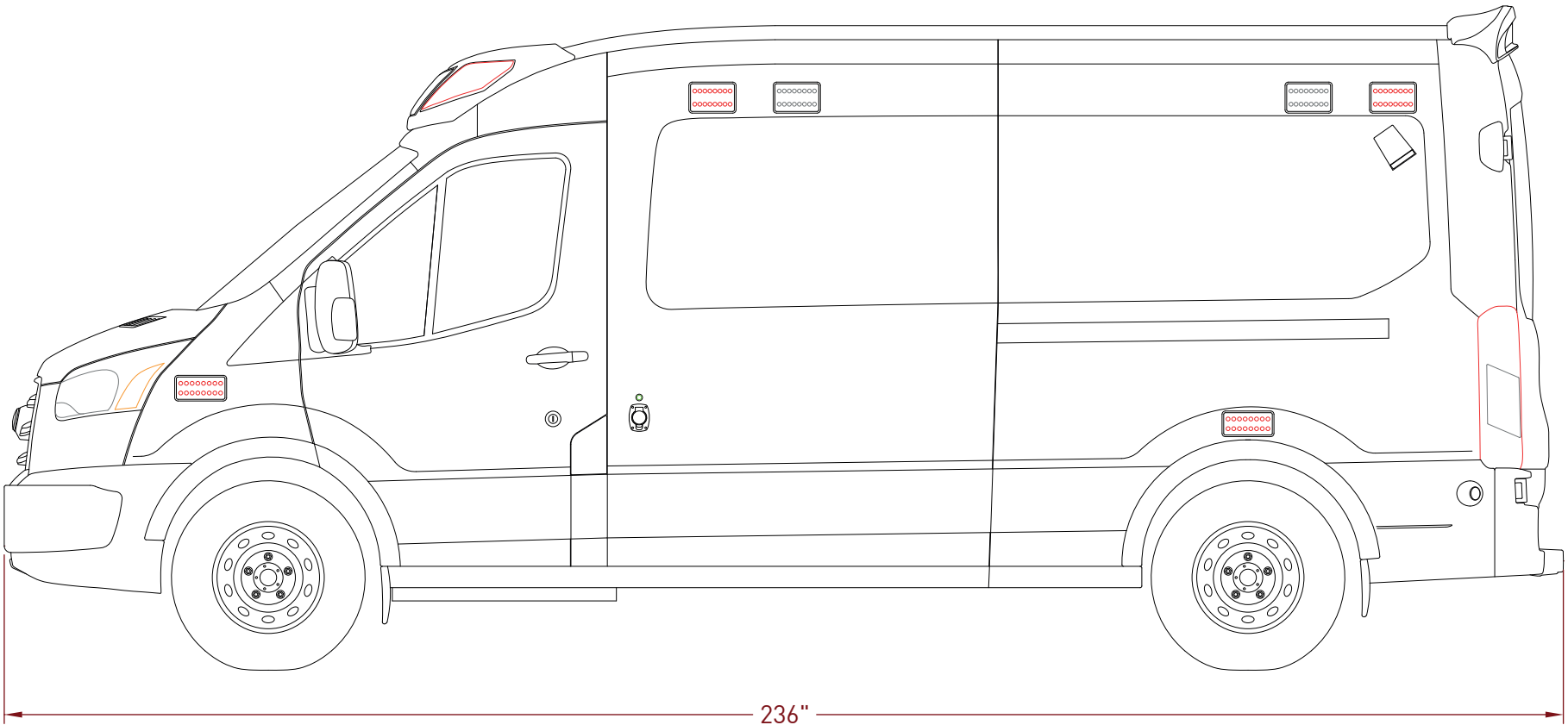

Front & rear exterior

Date: 2021-11-08 rev.1
Scale: 1:25
Draftman: TT

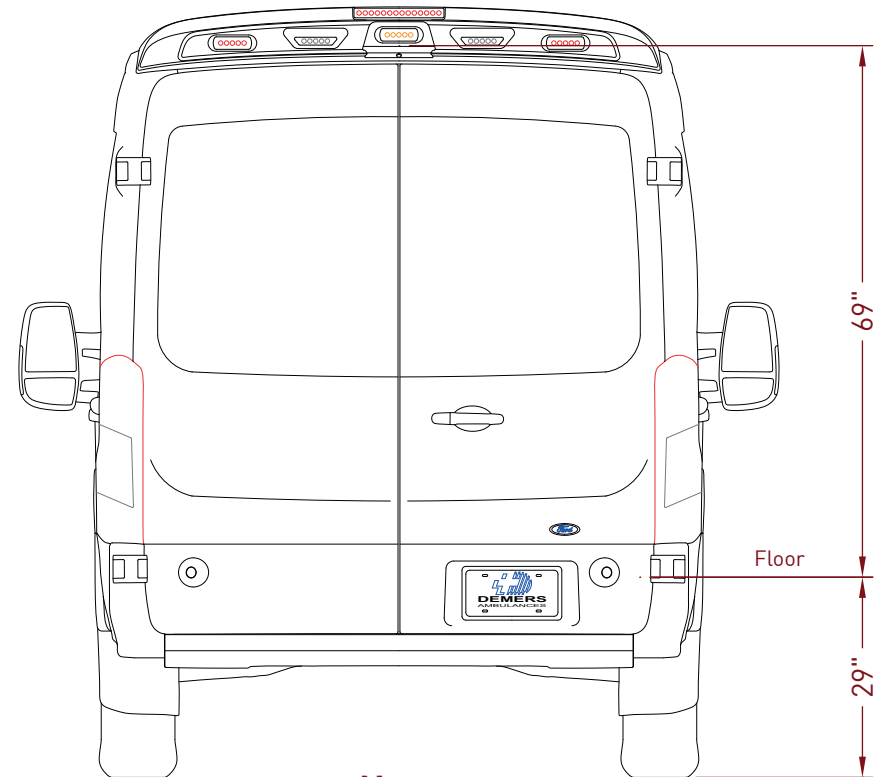
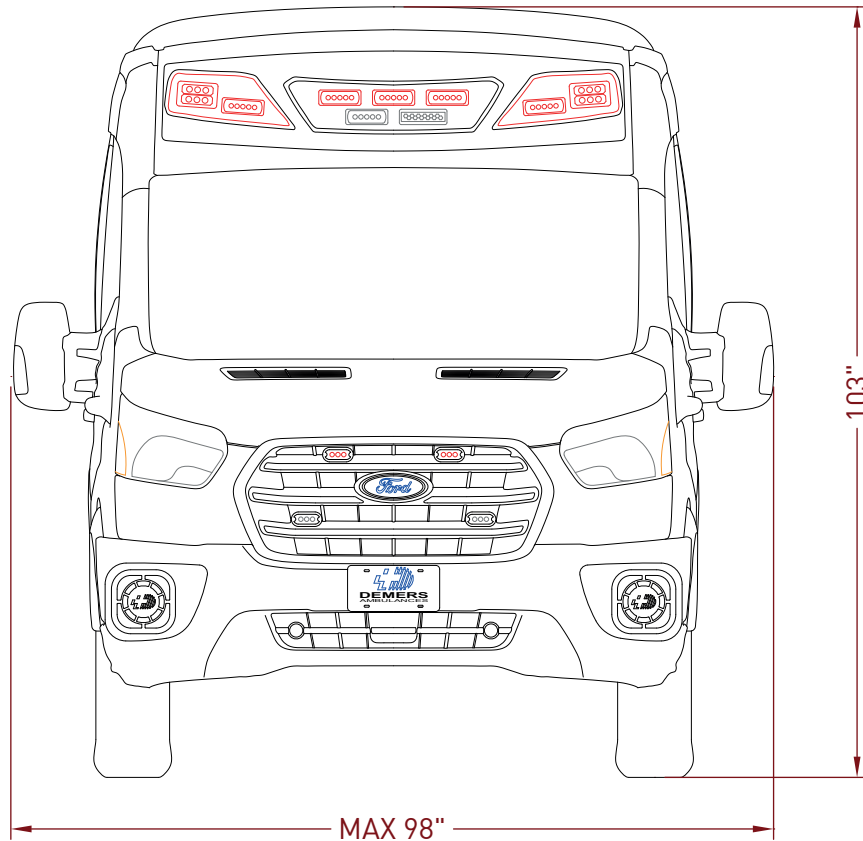

Note

The total height of the vehicle and the loading height can be different according to chassis and suspensions

Curbside interior wall

Date: 2021-11-08 rev.1
Scale: 1:20
Draftman: TT

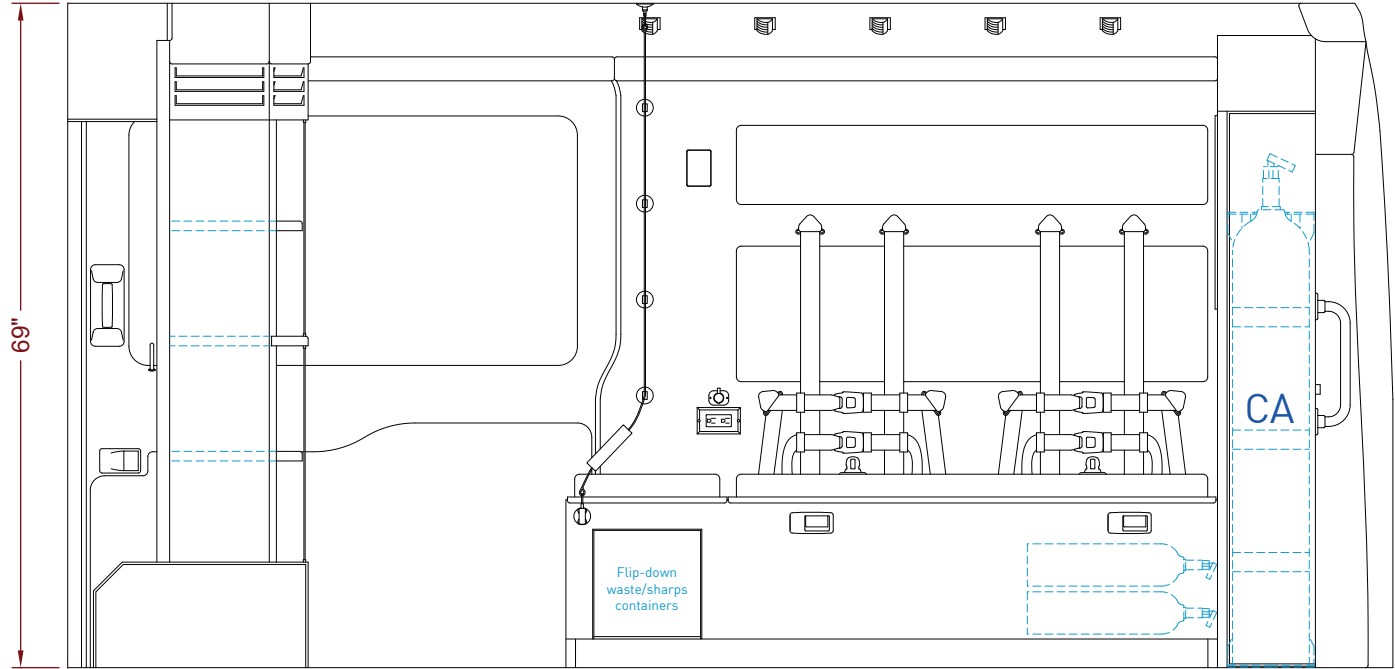

| COMPARTMENT | DIMENSIONS L x H x D |
|-------------------|--------------------------|
| Oxygen comp. - CA | 10.00" x 63.25" x 10.00" |

Streetside interior wall

Date: 2021-11-08 rev.1
 Scale: 1:20
 Draftman: TT

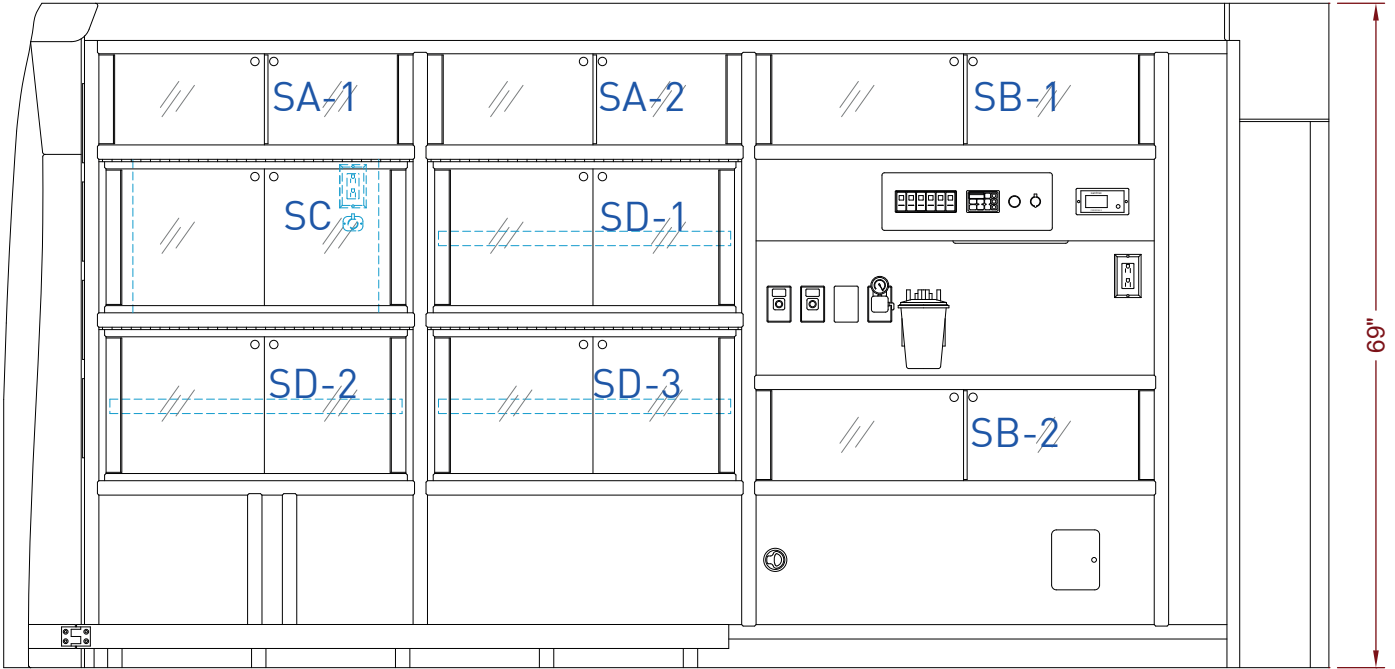

| COMPARTMENT | DIMENSIONS L x H x D |
|----------------------|--------------------------|
| Medical cabinet - SA | 33.00" x 10.00" x 7.50" |
| Medical cabinet - SB | 42.00" x 10.00" x 7.50" |
| Medical cabinet - SC | 33.25" x 16.75" x 11.25" |
| Medical cabinet - SD | 33.00" x 16.25" x 9.50" |

Front interior wall

Date: 2021-11-08 rev.1
Scale: 1:20
Draftman: TT

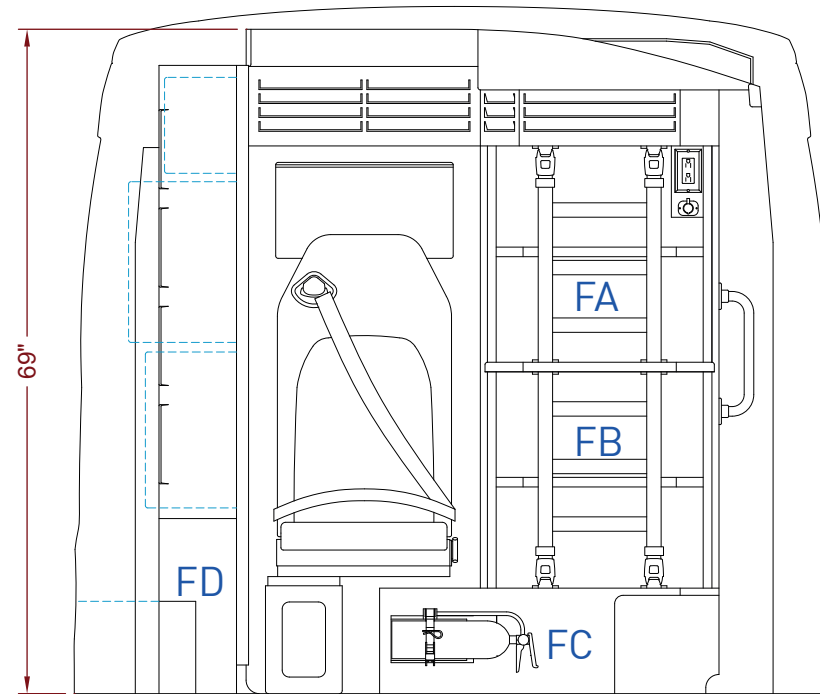

| COMPARTMENT | DIMENSIONS L x H x D |
|------------------------|--------------------------|
| High ALS comp. - FA | 24.50" x 22.50" x 12.75" |
| Low ALS comp. - FB | 24.50" x 23.00" x 12.75" |
| Stair chair comp. - FC | 35.00" x 10.75" x 22.00" |
| Backboard comp. - FD | 8.00" x 18.50" x 69.00" |

Rear interior wall

Date: 2021-11-08 rev.1
Scale: 1:20
Draftman: TT

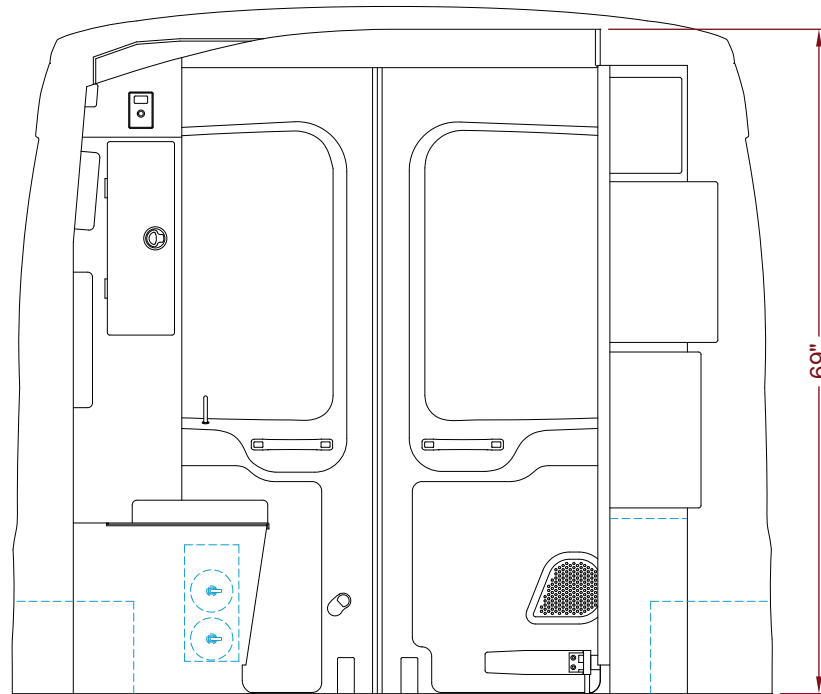

Floor view

Date: 2021-11-08 rev.1
Scale: 1:25
Draftman: TT

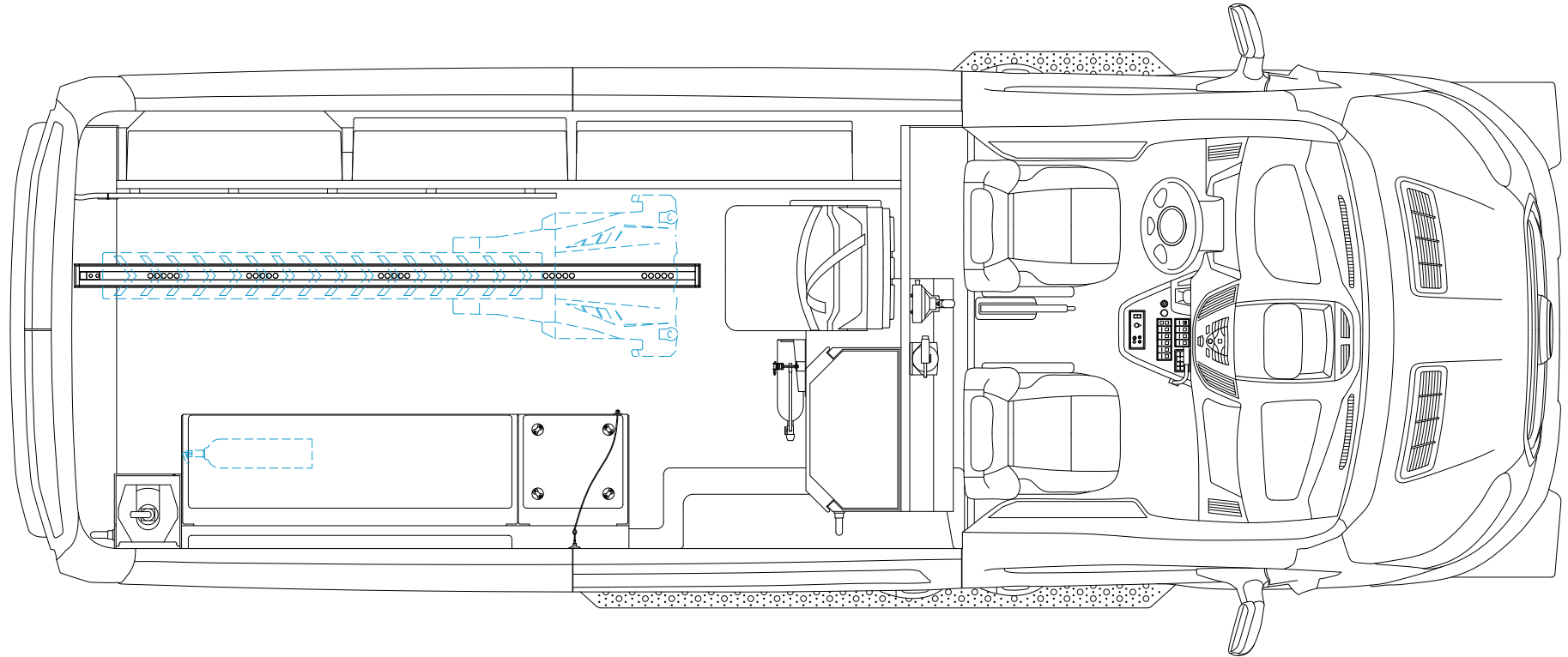

Ceiling view

Date: 2021-11-08 rev.1
Scale: 1:25
Draftman: TT

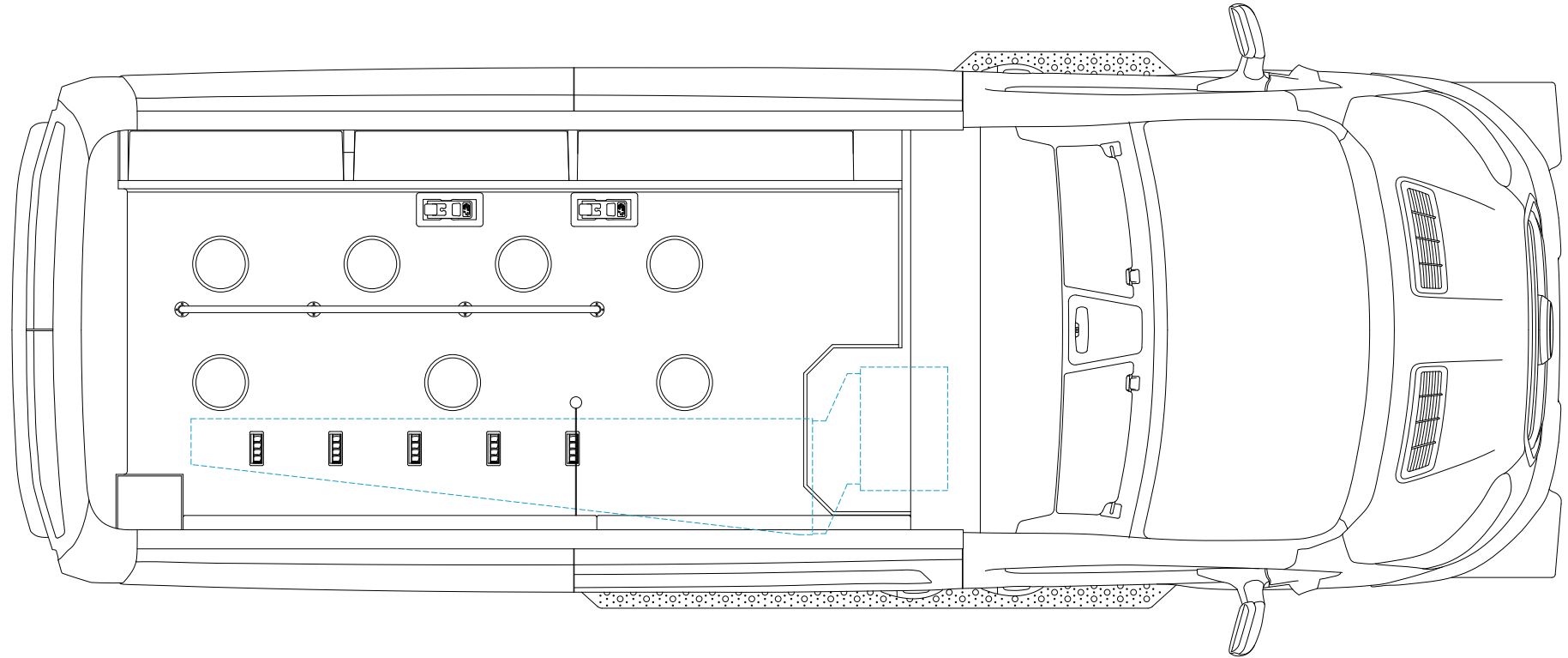

Front console

Date: 2021-11-08 rev.1
Scale: 1:3
Draftman: TT

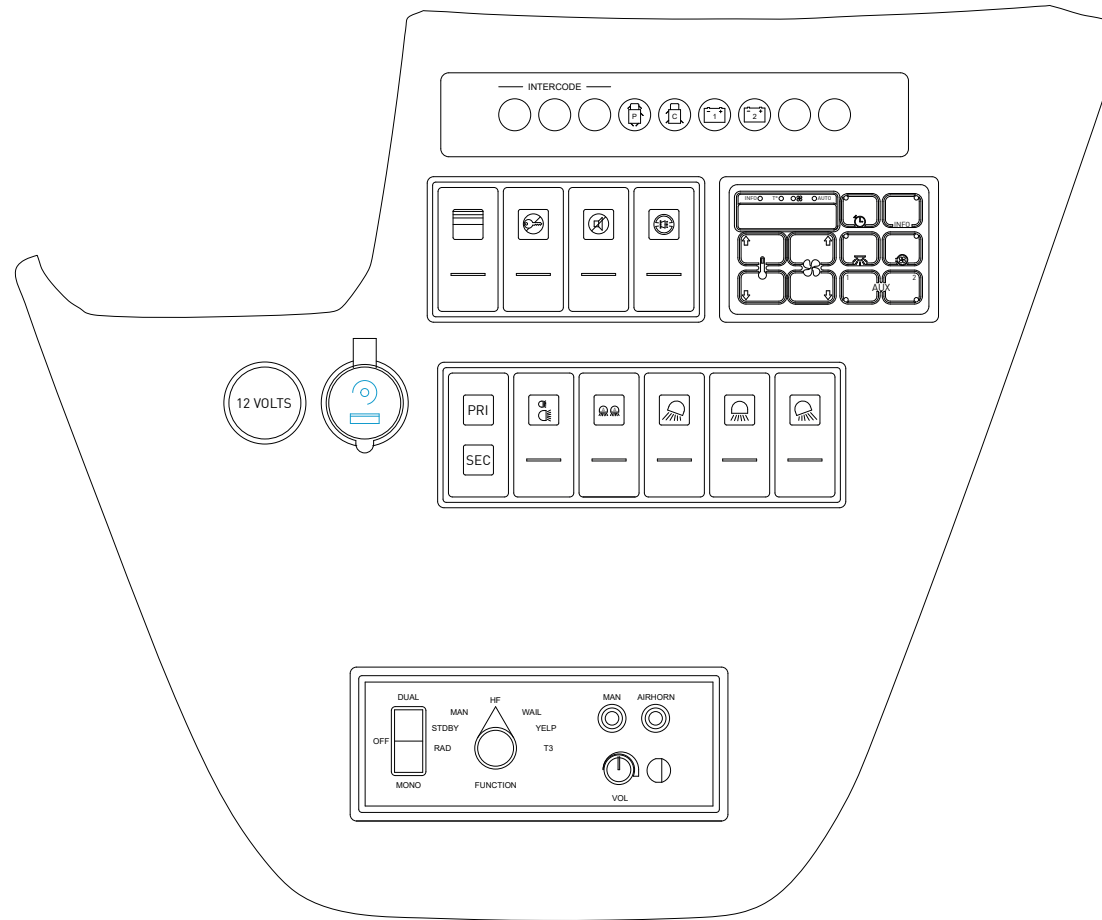

Streetside console

