

KME FLEX PUMPER | GSO 11710

AVAILABLE FOR QUICK DELIVERY

MODEL YEAR 2024

STARTING AT

\$736,898

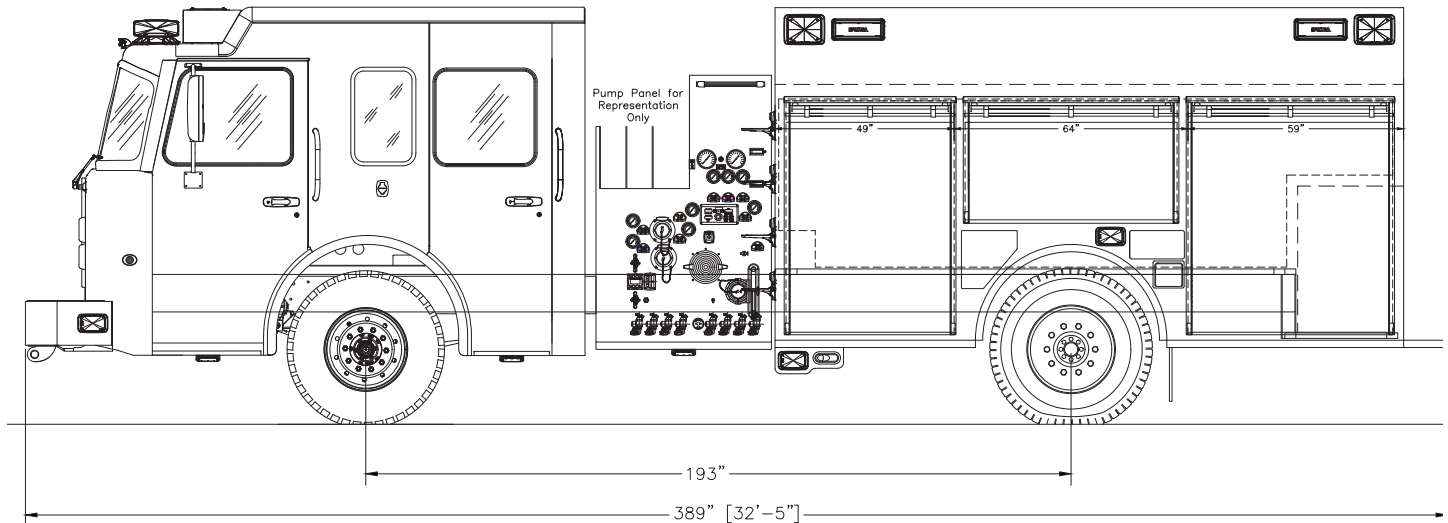

CHASSIS

- KME Panther XMFD 10" Raised Roof
- Cummins X12 500 HP
- Allison EVS 4000 Transmission
- Seating: 6-man cab
- USSC Valor Seats
- Front Axle: 22,000 lbs.
- Rear Axle: 27,000 lbs.
- Wheelbase: 193"
- Extreme Duty Interior
- 18" Front Bumper Extension
- Rear View Back-up Camera

PUMP & PLUMBING

- Side Mount Control Pump
- Waterous CSU 1500 GPM
- 1000 Gallons Water
- 20 Gallons Foam
- Future Foam System Capable
- 2" Tank Fill
- 3" Tank to Pump
- 3" Right Side Discharge
- (2) 2.5" Left Side Discharges
- 4" Right Side Discharge
- 2.5" Right Side Discharge
- 2.5" Left Rear Discharge
- 1.5" Front Bumper Discharge
- (2) 1.75" and (1) 2.5" Crosslay
- 3" Deck Gun Discharge
- TFT Extenda-Gun

BODY

- 3/16" High Strength Aluminum Body
- Amdor Roll-up Doors
- Durable Compartment Finish
- Full Height w/Slit Depth Compartments
- Federal Signal LED Lighting Package
- Ladder Storage for 24', 14', 10' Attic Ladder, Two std Pikes

Ask about our custom upfits tailored to your department's needs.



888-515-5145

CONTACT US TODAY

bulldogfireapparatus.com



KME FLEX PUMPER | GSO 11710

AVAILABLE FOR QUICK DELIVERY

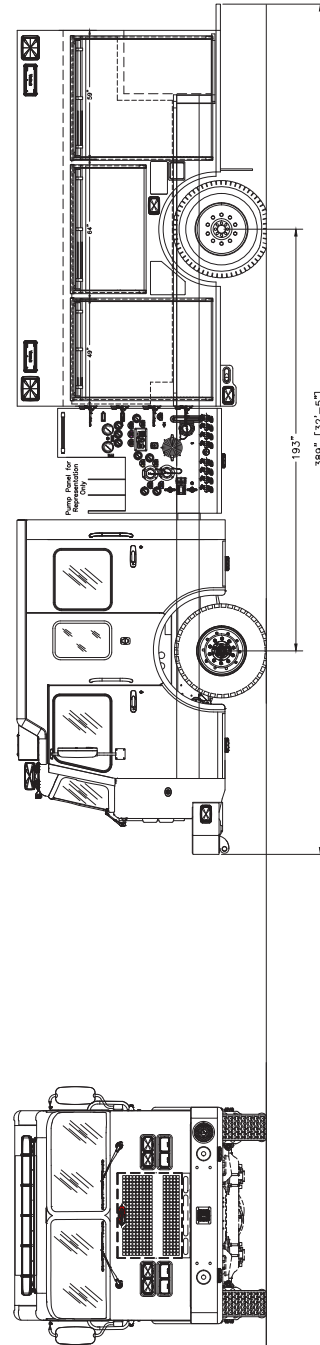
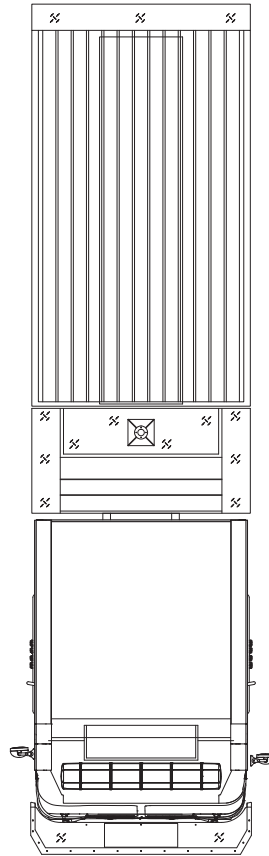
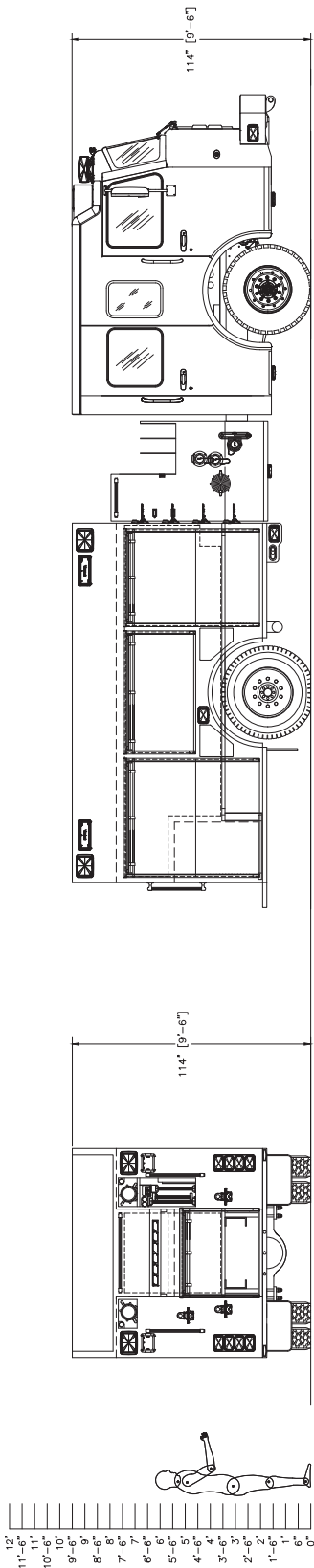

888-515-5145
 CONTACT US TODAY
 bulldogfireapparatus.com

